

**4.75 IN/120.65MM
 TORPEDO DIA.**

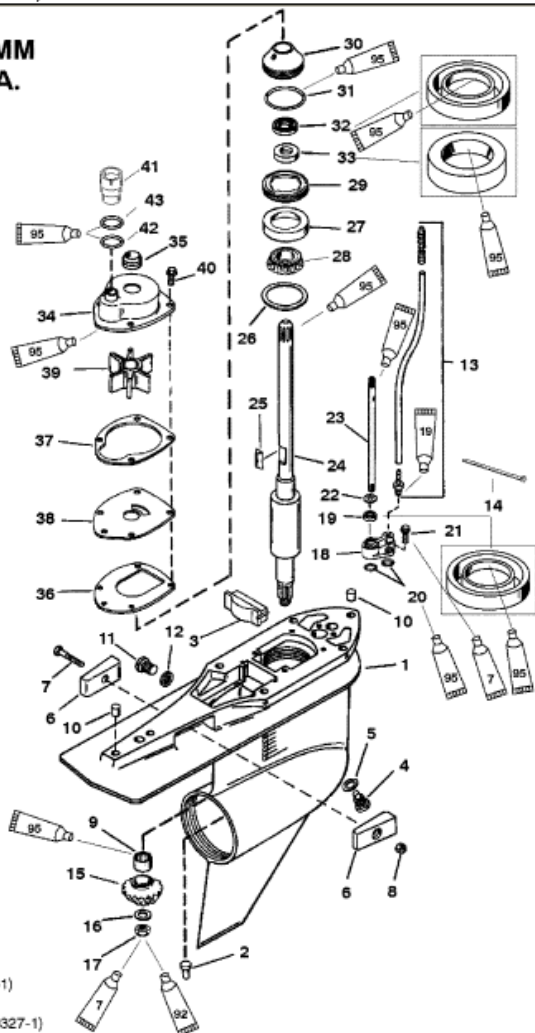

- Loctite "271" Adhesive Sealant (92-809819)
- Perfect Seal (92-34227-1)
- Loctite Primer "N" (92-59327-1)
- 2-4-C w/Teflon (92-850736A1)

Parts List

Ref	Class	Part	Description	Qty	Comment	Footnote
1	1623	859399T18	GEAR HOUSING	1	(BASIC)	
2	17	37972 1	PIN	1		
3		821526	FILLER BLOCK	1		
4	22	67892A 1	MAGNETIC SCREW	1		
5	12	19183	SEALING WASHER	1		15
6		826134Q	ANODE	2		
7	10	40003 33	SCREW	1		
8	11	826833 6	NUT	1		
9	31	42647A 1	ROLLER BEARING	1		
10	17	43044	DOWEL PIN	2		
11	10	79953A 2	SCREW ASSEMBLY	1		
12	12	19183	SEALING WASHER	1		15
13	22	85822A10	CONNECTOR	1	(L/XL)	
13	22	85822A 6	CONNECTOR	1	(XXL)	
14		56762	CABLE TIE	1		
15		NSS	PINION GEAR (PART OF 43-8281)	1	(1.75:1 - 12/21)	
15		NSS	PINION GEAR (PART OF 43-8281)	1	(1.87:1 - 15/28)	
16	12	92721	WASHER	1		
17	11	35921	NUT	1		
18	23	815921A 4	BUSHING ASSEMBLY	1		
19	26	816464 1	OIL SEAL	1		15
20	25	36318	O RING	2		15
21	10	19937 16	SCREW (M6 X 16)	2		
22	12	77674	RUBBER WASHER	1		
23		824145	SHIFT SHAFT (LOWER)	1		
24	45	816472	DRIVE SHAFT (LOWER)	1		
25	28	43037	KEY	1		18
26	15	42637A 1	SHIM	AR		
27	31	36387A 1	TAPERED ROLLER BEARING	1		
28		NSS	CUP	1		
29		824519	RETAINER	1		
30		807929A 1	CARRIER ASSEMBLY	1		18
31	25	90011	O RING	1		15,18
32	26	66302	OIL SEAL	1		15,18
33	26	66302	OIL SEAL	1		15,18
34		817275A 1	WATER PUMP ASSEMBLY	1		18
35	26	816575A 2	SEAL	1		15,18
36	27	43033 1	GASKET	1		15,18
37	27	817277 1	GASKET	1		15,18
38		817276 1	FACE PLATE	1		18
39	47	4206T 2	IMPELLER	1		18